

Roll-Away® Series 6500

The Disappearing Screen Door
Installation Instructions

(For Surface Mount Doors)

Form: M15213
Rev: 08/06/03
Page 1 of 5



IMPORTANT: REVIEW ALL INSTRUCTIONS THOROUGHLY BEFORE STARTING STEP 1

Tools Required

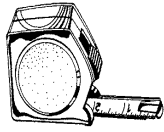

Tape Measure

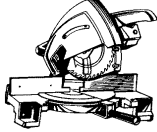

Hack or
Chop Saw



Drill Motor &
1/8", 3/16" Drill
Bits



Phillips Head
Screwdriver



Pencil or
Scriber

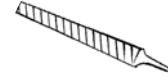

File

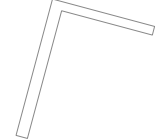

Framing Square



Strike
#D2160



#4 Lock Nut



Pan Head
#4-40 x 1/2"

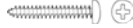

Pan Head
#8 x 1"

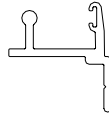

Sill Track
R6041



Closer
R6051

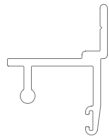

Head Track
R6046



Partially Assembled Unit

Parts Included

Step 1

Fabricate / Verify Part Lengths Required

Note: Please refer to page one of these instructions and verify your screen dimensions, and operation.
Please refer to page two and verify your clearances.
If your unit was purchased as a "kit" please refer to page 1 and the fabrication instructions.
If your unit was purchased "assembled" the following has already been cut to size, verify and proceed to step 2.

Closer (#R6051)
Screen height (Step 1) minus 1 1/8"

Track (#R6041 & #R6046)
Screen width (Step 1) minus 3 1/8"

The completed hinge/housing assembly should measure your screen height minus 1 1/8".

Step 2**Install Housing/hinge**

Drill three (3) 3/16" holes in the housing hinge, one approximately 2" from each end, one approximately in the middle. Locate the holes using the groove in the hinge flange.

Carefully, making sure not to damage the screen, install the Housing hinge against the stop in the jamb using three (3) #8 x 1" pan-head screws provided. The hinge should extend past the opening 1/2" head and sill. Insure the housing is fully snapped onto the hinge. **NOTE: It is the responsibility of the installer to insure the installation screws are firmly fixed in a suitable substrate. R. Lang Company makes no implication that the screws provided are suitable for every application, and will not be responsible for damage, poor operation, or failure that result from improper installation.** Lock the hinge to the housing using one (1) #6 x 3/8" pan head screw provided.

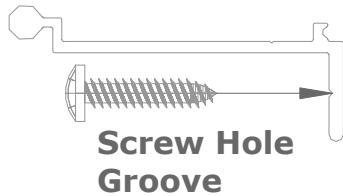

Make sure the housing ends are aligned with the hinge ends, and lock the hinge to the housing, using the #6 x 3/8" pan head screw provided.

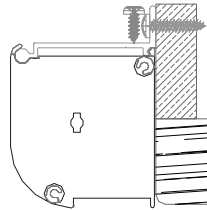

Place the hinge against the jamb as shown, and screw it into place.

Make sure the housing is fully seated on the hinge.

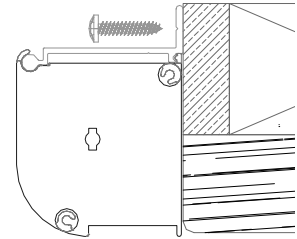
**Step 3****Install Tracks**

Drill three (3) 3/16" holes in each track, one approximately 2" from each end, one approximately in the middle. Locate the holes using the groove in the track flange. Insert the head track into the drawbar wheel housing, and slide it into the pocket in the housing end cap. Carefully align the track with the housing, using a framing square to insure accuracy. Make sure the track is fully seated in the housing end cap pocket and attach the track to the opening using the #8 x 1" pan head screws provided. **NOTE: It is the responsibility of the installer to insure the installation screws are firmly fixed in a suitable substrate. R. Lang Company makes no implication that the screws provided are suitable for every application, and will not be responsible for damage, poor operation, or failure that result from improper installation.** Repeat this process for the sill track.

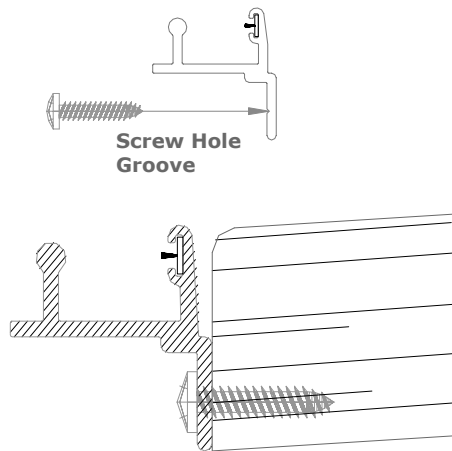

Track attached. Note its relation to the opening edge.

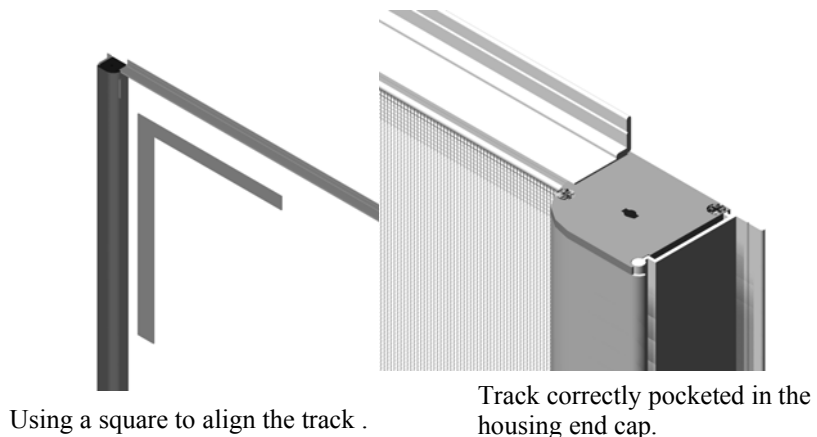

Using a square to align the track .

Track correctly pocketed in the housing end cap.

Step 4

Drill three (3) 3/16" holes in the closer (#R6051), two approximately 4" from each end, one approximately in the middle using the groove in the closer flange. The closer is designed to pocket the tracks. It may be installed without modifying the tracks, leaving a small gap. For a flush fit, the tracks may have a slight radius trimmed on them with a file as shown. Install Closer over the ends of the tracks using #8 x 1" pan head screws provided, on the jamb opposite the housing.

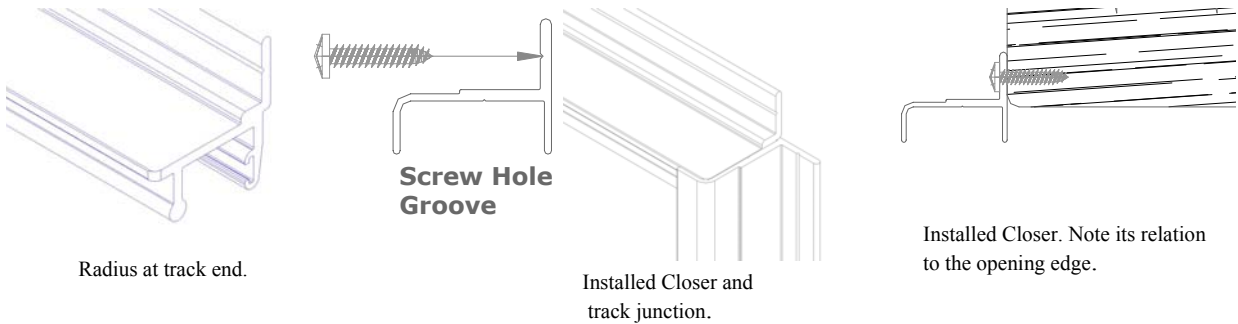
**Step 5****Strike Installation.**

The strike (D2160) is mounted nose down, using the #4-40 x 1/2 screws and lock nuts provided. The mounting holes for the strike must be located along the alignment groove provided inside the closer. The nose of the strike should be approximately 1/8" below the latch, as measured from the sill track. The strike holes will locate 3/4" and 1 1/4" above this point. Adjust the strike up or down as needed to get a secure latch. **WARNING!** Adjusting the strike too far down will not allow the latch to engage the strike.

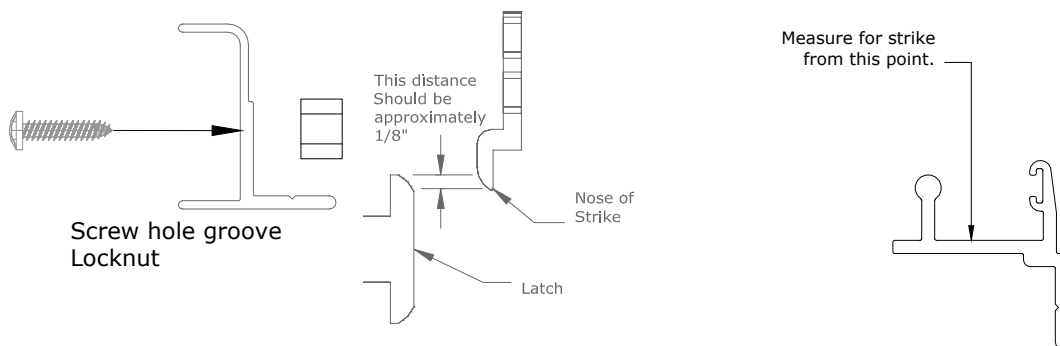
**Installation Complete**

Make sure all components are properly installed. Check the overall operation of the door. Drawbar guides should move freely over both the bottom and top tracks and connect squarely with the closer. If properly installed, the door will want to return to the housing quickly after breaking contact with strike.

Roll-Away® FRENCH DOOR SYSTEM ONLY**Amendments To Fabrication Instructions For French Door Opening**

A French Door, or double-door opening, does not require a closer. Instead, the drawbars from each door meet in the middle. Astragal pins and astragal (R5180) on one of the doors are necessary in order to create a “stationary” panel. Astragal pin and astragal installation is done at the factory on assembled units. French door sets include 2 door systems, but only 1 top track, and 1 bottom track to cover opening. The following steps are necessary to prepare a KD kit for installation.

1. Determine which door will be stationary.
2. This side will use the drawbar with the astragal installed. Note: Astragal pins are shipped in the drawbar, pins inward.
3. Slide the Astragal off the drawbar, and cut the drawbar to the drawbar length needed for your screen height (Screen height minus 3 9/16”). You may wish to cut evenly from both ends. Cut the same amount from each pin that you removed from that end of the drawbar.
4. Cut the Astragal to the screen height minus 1 11/16”. Astragals are provided with machining designed to extend the Astragal into the track. If you have cut the drawbar evenly at both ends, you may do the same with the Astragal and reproduce the machining with a hacksaw and file. Deburr the pins, and slide the astragal back into the drawbar, inserting the pins into the drawbar groove, pin out..
5. Slide drawbar assembly onto screen, and attach drawbar end caps (Guides).

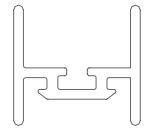

R5180



R5450

Change**Amendments To Installation Instructions For French Door Opening****2: Install Housing/hinge**

Install both Housing/hinge assemblies in the jambs directly opposite of each other.

Step 3: Install Tracks

Both doors in a French Set will travel along the same tracks. (Note: If you purchased a French door kit as a KD, you will need to cut the head and sill tracks to the screen width minus 5 1/8”. Example: If your screen width is 72” then cut the tracks at 66 7/8”. It is strongly recommended that measurements are taken at the head and the sill, and the tracks cut specifically to fit these dimensions.) The track pocket method may only be used on one side of the door. The opposite drawbar must be “snapped” into place after the tracks are installed. It is important that the tracks be fully seated in the housing end cap pockets for proper door operation. To avoid damaging the screen, it is recommended that you temporarily tape or otherwise restrain the drawbar/screen that will be “snapped in” out of the track area while the tracks are being installed. Install the tracks per step

3, pocketing the tracks in the opposing housing end caps (instead of the closer). Use the #8 x 3/4 flat head screws provided to secure the tracks to the opening.

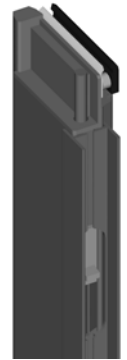

Drawbar & Astragal Pin
Astragal Pin (#R5450) in
Slot in Drawbar.

New**Step 4: Install Closer**

Step 3—Closer is not required. Strike installs in astragal.

“Snapping” in the opposite door.

Carefully - and while making sure the screen is properly guided within the Head and Sill Tracks-Pull on center of Drawbar until approximately two (2) feet of screen is exposed. Line up the top Drawbar Guide with the Head Track, and the bottom Drawbar guide with the Sill Track (this will require the drawbar to be at a slight angle) and “snap” into place. Allow the screen to retract back into the housing. It is necessary to keep the Drawbar Guides aligned with the tracks during this process to prevent damage to the Guide assemblies.

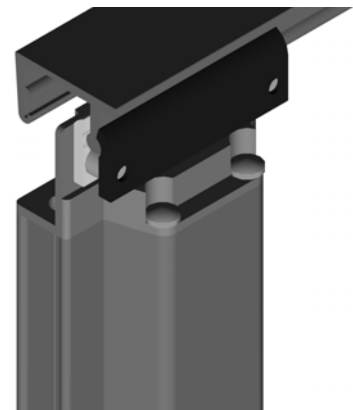

“Snap” the guide onto the track.

Roll-Away® FRENCH DOOR SYSTEM ONLY**NEW: Install Astragal Stops**

Install Astragal Stops (#R6490/6495) into head and sill track. Fasten using one (1) #6 x 3/8" flat head screw through hole and into track. The astragal block stop upright will point at the operable door. The astragal block will locate along the wheel housing track. Make sure stops are evenly placed, top and bottom, and hold stationary door in required position. The stop upright should be placed at that position in the track. Operable door should easily open and close, latching at the stationary door when required. If more depth for the astragal pins is desired, a 7/32" drill bit can be used to drill through the astragal stops into the track.

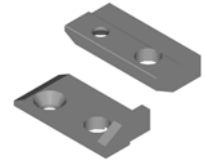

Part #R6490/95 Astragal Stop

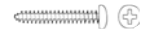
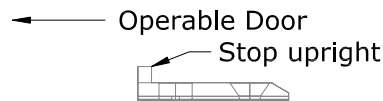
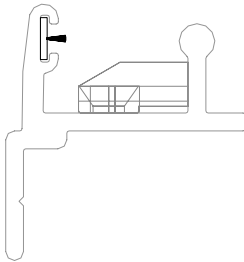
**Astragal
Block location**Pan Head
#4 x 3/4"**Finish: Install Strike**

Follow the instructions in Step 6 for installation of the strike, installing it in the astragal R5180 instead of a closer. You must use the #4 x 3/4 pan head sheet metal screws for this application.

Roll-Away® LIMITED WARRANTY

To the original purchaser, R. Lang Company warrants this product and its components parts to be free of defects on materials and workmanship.

Damage caused by accident, improper installation or abuse, is specifically excluded from this warranty. Manufacturer's liability on any claim shall not exceed the cost of the product. In no instance shall manufacturer be responsible for consequential damage from the use of this product, including damage to existing door during installation or operation.

Any defective product or part may be sent, freight prepaid, to R. Lang Company, 8240 West Doe Avenue, Visalia, California (93291) for replacement or repair at no charge. Proof of purchase date must accompany any returned item. For further information about this warranty, write to Consumer Affairs Manager at R. Lang Company.

This warranty replaces any and all previous warranties, either written, oral, or implied, and is the only warranty made on this product by the R. Lang Company. This warranty gives you specific legal rights. Rights may vary from state to state.